



Agilent Technologies

Agilent

Stethos

Electronic Stethoscope

Users Guide for Stethos Electronic Stethoscope

Electronic Stethoscope
Elektronisches Stethoskop
Stéthoscope électronique
Estetoscopio electrónico
Stetoscopio elettronico
Estetoscópio eletrônico
Elektronische stethoscoop
Elektroninen stetoskooppi
Elektronisk stetoskop
Elektroniskt stetoskop
Elektronický fonendoskop
Elektronikus sztetoszkóp
Stetoskop elektroniczny
Elektronik steteskop
Elektronisk stetoskop
электронный стетоскоп
Ηλεκτρονικό Στηθοσκόπιο
電子聽診器
电子听诊器

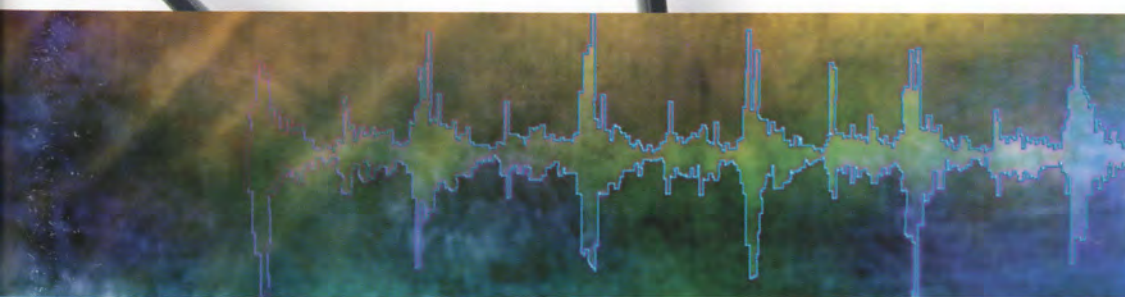

Stethos

CE 0123

| | |
|---|-----------|
| STETHOS Electronic Stethoscope Operating Instructions | 1 |
| STETHOS Elektronisches Stethoskop Benutzerhandbuch | 3 |
| Stéthoscope électronique STETHOS Mode d'emploi | 5 |
| STETHOS Elektronische stethoscoop Gebruikershandleiding..... | 7 |
| Stetoscopio elettronico STETHOS Istruzioni per l'uso | 9 |
| Estetoscopio electrónico STETHOS Instrucciones de funcionamiento | 11 |
| Estetoscópio Eletrónico STETHOS Manual do Utilizador..... | 13 |
| STETHOS, elektroniskt stetoskop Bruksanvisning | 15 |
| Elektroninen STETHOS stetoskooppi Käyttöohjeet..... | 17 |
| STETHOS, elektronisk stetoskop Brugervejledning..... | 19 |
| Ηλεκτρονικό Στηθοσκόπιο STETHOS, της Οδηγίες Λειτουργίας | 21 |
| STETHOS, elektronisk stetoskop Bruksanvisning | 23 |
| Электронный стетоскоп STETHOS Руководство пользователя | 25 |
| Stetoskop elektroniczny STETHOS Instrukcja obsługi..... | 27 |
| STETHOS Elektronický Fonendoskop Provozní pokyny | 29 |
| STETHOS Elektronikus sztetoszkóp Felhasználói kézikönyv | 31 |
| STETHOS Elektronik Stetoskop İşletme Talimatları | 33 |
| STETHOS 電子聽診器 取扱説明書 | 35 |
| STETHOS 电子听诊器 使用说明 | 37 |
| STETHOS 電子聽診器 使用說明 | 39 |

STETHOS Electronic Stethoscope

Operating Instructions

Introduction

Congratulations! The STETHOS electronic stethoscope you have purchased is the result of years of research and development to provide you the ultimate in medical auscultation.

Technical Features

General Features

With its built-in micro-chip, your new STETHOS is at the cutting edge of technology. Its main features include:

- Fully electronic design eliminates sound loss and resonance effects
- Bell, Diaphragm and Extended Diaphragm modes with 8 levels of sound amplification
- Hand tremor and ambient noise filtering with auto impact noise muting and auto shut-off for extended battery life
- Ergonomically designed to look and feel like your traditional stethoscope

Frequency Response

The key to the success of STETHOS is its similarity with high fidelity stereo systems, which include an amplifier and an equalizer that allow the user to obtain sound amplification as well as a controlled frequency response.

This unique feature lets you amplify sounds within the range of the standard Diaphragm and Bell modes, while minimizing undesirable frequencies. Thus, it is possible to reduce interference caused by ambient noise. The Extended Diaphragm mode also enables you to hear high frequency sounds such as those produced by mechanical valvular cardiac prostheses.

The following chart shows the improved frequency response provided by STETHOS over conventional stethoscopes.

The below graph demonstrates how the STETHOS amplifies the preferred low frequency sounds while reducing the undesirable high frequency ambient noise.

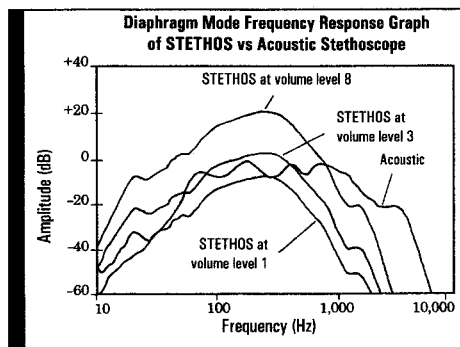

Operating Instructions

Headset Fitting

To ensure optimal transmission of sound, STETHOS was developed with the ear morphology in mind. The earphones are thus identified by the letters R (right) and L (left).

Tension Adjustment

To ensure maximum comfort for the user's ears, STETHOS is equipped with a roll-on tension adjustment sleeve. Once adjusted, pressure is maintained at a constant level.

Power On

To turn on the instrument, press the \odot key located at the center of the chest piece. A red light will flash to indicate that the Diaphragm mode is activated.

Mode Selection

To set to the Bell mode, press the \odot key and wait for the green light to flash. The \ominus key allows you to alternate between the Diaphragm and Bell modes during auscultation. To access the Extended Diaphragm mode, press and hold the \odot and \oplus keys simultaneously. The red light will flash 3 times.

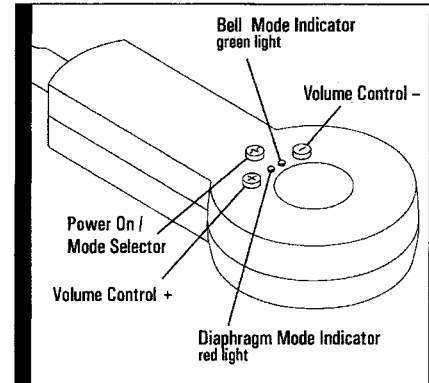

Volume Control

To increase the volume level, press the \oplus key. To lower it, press the \ominus key. STETHOS has 8 volume levels. In the Diaphragm and Extended Diaphragm modes, the red light will flash to indicate a change in volume level. In the Bell mode, the green light will flash to indicate a volume change. If the light (red or green) does not flash, the minimum (1) or maximum (8) level has been reached.

Programming Volume Level

To save your preferred volume, simply adjust it to your desired level and press the \odot key and \ominus key simultaneously. The light will flash 3 times. Your STETHOS will automatically reach this pre-programmed volume as soon as it is activated. The volume can be reprogrammed by repeating these steps.

Power Off

To turn off the instrument, simply press the \oplus and \ominus keys simultaneously and the red and green lights will flash once. This step can be avoided as the instrument's automatic shut-off feature will turn the device off two minutes after activating the last key.

Low Battery Indicator

The simultaneous flashing (3 times) of the green and red lights, when the instrument is turned on, is an alarm indicating that the batteries must be replaced.

Replacing Batteries

To replace the batteries in your STETHOS:

1. Unscrew the non-chill ring by pressing it firmly against the palm of your hand.
2. Slide off the battery cover.
3. Remove the batteries. (Please discard in an environmentally safe manner.)

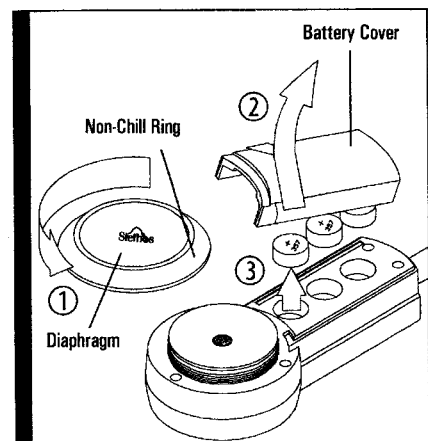

To reassemble the chest piece, repeat these steps in reverse order. However, to

screw the Non-Chill Ring back on, it is preferable to turn the chest piece upside down while pressing on the Battery door.

In view of the low power consumption of your STETHOS, batteries will operate for approximately one year under normal use. Replacement batteries must be type 357.

The batteries are not intended to be recharged. If you are not using your STETHOS for a period, beyond expected life of battery, it is suggested you remove the batteries.

Replacing Eartips

To ensure optimal comfort, two types of Eartips are supplied with your STETHOS. To replace them, simply unscrew the tips and replace them with the alternative pair.

Maintenance

STETHOS requires no specific maintenance. However, in order to reduce the risk of cross contamination, we recommend wiping the stethoscope clean with alcohol. The eartips should be cleaned periodically to prevent cerumen build-up.

Avoid exposure to extreme temperatures and any contact with concentrated solvents. Do not immerse your stethoscope in any liquid.

There are no user serviceable parts with exception of the batteries inside the STETHOS.

Warranty for your STETHOS

Every STETHOS is warranted against defects in materials or workmanship for a period of one year from purchase date. During the warranty period, Agilent Technologies will, at its option, either repair or replace components or product which prove to be defective.

The foregoing warranty shall not apply to defects resulting from unauthorized modifications or misuse by Buyer. No other warranty is expressed or implied, Agilent Technologies specifically disclaims the implied warranties or merchantability and fitness for a particular purpose.

Packaging Symbols



Latex-Free



Consult guide for more information



Complies with CAN\CSA-C22.2 no. 601.1-M90 and UL2601-1 standards



Type BF: Degree of protection against electric shock

Parts Ordering and Service

The following replacement parts are available:

- M4504-60050 Replacement Batteries
- M4504-60000 Eartips soft, 12.7mm
- M4504-60010 Eartips firm, 13.3mm
- M4504-60020 Diaphragm
- M4504-60030 Non-chill ring
- M4504-60040 Battery cover
- M4504-91000 User's manual

Use only Agilent Technologies approved parts, using any other parts or materials can degrade performance, including safety.

For parts ordering, technical specifications and service information, contact an Agilent Technologies specialist near you or visit our websites at

www.agilent.com/healthcare/stethos
www.agilent.com/healthcare/medsupplies

See back inside cover for country location and phone number.

Technical Specifications

Supply voltage 4.5 VDC
Supply current 1mA (typ)

Operating Environment

Temperature -5°C to 60°C
Humidity 20 to 95 %RH
Altitude up to 4550m
Degree of protection against ingress of water: IPX0

Degree of safety of application in the presence of a flammable mixture with air or with oxygen or nitrous oxide: Equipment not suitable for use in the presence of a flammable anesthetic mixture with air or with oxygen or nitrous oxide.

Storage Environment

Temperature -40°C to 70°C
Humidity 15 to 95 %RH
Altitude up to 4550m

Radio Frequency Electromagnetic Field

as per EN 60601-1-2 (1993)

Intended Use

The Stethos electronic stethoscope is intended for the purpose of electronically amplifying and listening to biological sounds, such as the heart, arteries and veins and other internal organs.





Contraindications

Stethos is not intended as a substitute for medical care or for diagnosis and treatment by unlicensed or unsupervised/untrained persons. The Stethos electronic stethoscope is contraindicated for use other than listening to biological sounds.

Caution

Choking Hazard from small parts included with STETHOS. Keep out of reach of small children.

Basic Operating Functions



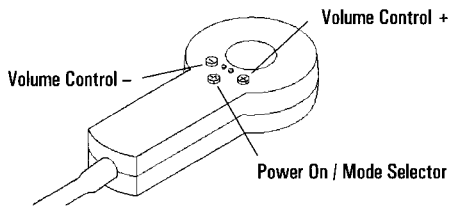

- Power On** 
- Diaphragm Mode**  red light one time
- Bell Mode**  green light one time
- To increase volume**  one time at each level
- To decrease volume**  one time at each level

Note: When the instrument is turned on, the red light flashes indicating that the diaphragm mode has been activated.





www.agilent.com/healthcare/stethos

Advanced Features

- Extended Diaphragm Mode**  
(red light flashes 3 times)
- Volume Programming**  
(red or green light flashes 3 times)



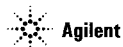

Note: When turned on, the instrument sets itself automatically to the pre-programmed volume.

- Power Off**  
or the instrument will shut off automatically after 2 minutes

- Low Battery Detector**
red and green lights flash 3 times only at Power On



Hauptsächliche Tastenfunktionen





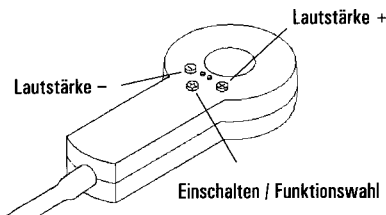

- Einschalten** 
- Membranmodus**  rote Lampe, einmal
- Trichtermodus**  grünes Licht, einmal
- Lautstärke erhöhen**  einmal pro Stufe
- Lautstärke verringern**  einmal pro Stufe

Hinweis: Wenn das Gerät eingeschaltet wird, blinkt die rote Lampe, um anzuzeigen, daß der Membranmodus aktiviert ist.





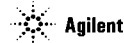

www.agilent.com/healthcare/stethos

Weitere Tastenfunktionen

- Erweiterter Membranmodus**  
(rote Lampe blinkt dreimal)
- Lautstärke speichern**  
(rote oder grüne Lampe blinkt dreimal)
- Hinweis:* Wenn das Stethoskop eingeschaltet ist, stellt es sich auf die gespeicherte Lautstärke ein.
- Ausschalten**  
oder das Gerät schaltet nach 2 Minuten automatisch ab
- Batteriewarnanzeige**
rote und grüne Lampe blinken dreimal, nur wenn das Gerät eingeschaltet ist.



Fonctions de base





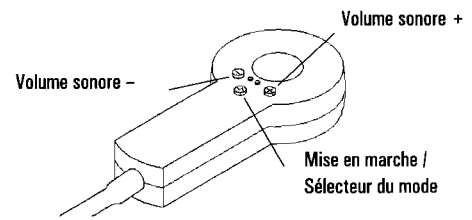

- Mise en marche** 
- Mode diaphragme**  voyant lumineux rouge, une fois
- Mode cloche**  voyant lumineux vert, une fois
- Augmentation du volume**  une fois à chaque niveau
- Diminution du volume**  une fois à chaque niveau

Note : Lors de la mise en marche de l'instrument, le voyant lumineux rouge clignote pour indiquer que le mode diaphragme est activé.





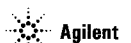

www.agilent.com/healthcare/stethos

Fonctions avancées

- Mode diaphragme étendu**  
(3 clignotements du voyant lumineux rouge)
- Programmation du volume sonore**  
(3 clignotements du voyant lumineux rouge ou vert)
- Note :* Lors de la mise en marche, l'instrument se règle automatiquement au volume sonore préprogrammé.
- Arrêt**  
ou l'appareil s'éteint automatiquement au bout de 2 minutes.
- Détecteur de piles faibles**
3 clignotements simultanés des voyants lumineux rouge et vert, lors de la mise en marche uniquement.



Elementaire bedieningsfuncties



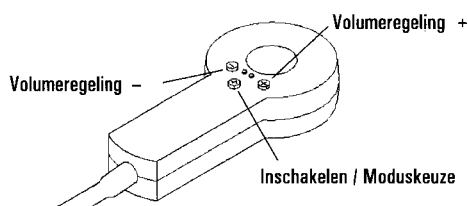

- Inschakelen** 
- Diafragrammodus**  rood lichtje eenmaal
- Belmodus**  groen lichtje eenmaal
- Volume verhogen**  eenmaal voor elk niveau
- Volume verlagen**  eenmaal voor elk niveau

N.B.: Wanneer het instrument wordt ingeschakeld, knippert het rode lichtje, wat betekent dat de diafragrammodus is geactiveerd.





www.agilent.com/healthcare/stethos

Geavanceerde functies

- Uitgebreide diafragrammodus**  
(rood lichtje knippert driemaal)
- Volume programmeren**  
(rood of groen lichtje knippert driemaal)





N.B.: Wanneer het instrument wordt ingeschakeld, wordt automatisch het voorgeprogrammeerde volume ingesteld.

- Uitschakelen**  
of het instrument wordt automatisch na 2 minuten uitgeschakeld

- Detectie lege batterij**
rood en groen lichtje knipperen driemaal, alleen bij het inschakelen.



Funzioni operative di base





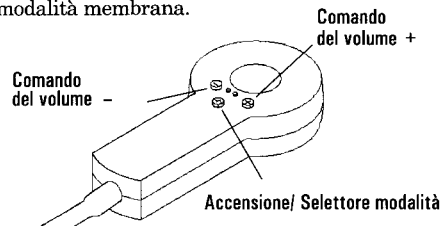

- Accensione** 
- Modalità diaframma**  spia rossa una volta
- Modalità campana**  spia verde una volta
- Per alzare il volume**  una volta per ciascun livello
- Per abbassare il volume**  una volta per ciascun livello

Nota: quando si accende lo strumento, la spia rossa lampeggia indicando che è stata attivata la modalità membrana.







www.agilent.com/healthcare/stethos

Caratteristiche avanzate

- Modalità diaframma estesa**  
(la spia rossa lampeggia 3 volte)
- Programmazione volume**  
(la spia rossa o verde lampeggia 3 volte)
- Nota:* quando si accende lo strumento, questo si porta automaticamente sul volume pre-programmato.
- Spegnimento**  
o lo strumento si spegne automaticamente dopo 2 minuti.
- Indicatore batteria scarica**
La spia rossa e verde lampeggiano 3 volte, solo all'accensione.



Funciones básicas





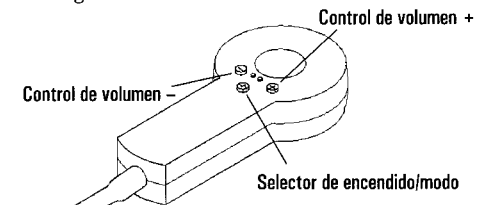

- Para encender** 
- Modo diafragma**  luz roja (una vez)
- Modo campana**  luz verde (una vez)
- Para aumentar el volumen**  una vez en cada nivel
- Para disminuir el volumen**  una vez en cada nivel

Nota: Al encenderse el instrumento, la luz roja parpadea indicando la activación del modo diafragma.



www.agilent.com/healthcare/stethos

Características avanzadas

- Modo diafragma extendido**  
(la luz roja parpadea tres veces)
- Programación del volumen**  
(la luz roja o verde parpadea tres veces)
- Nota:* Una vez encendido, el equipo se ajusta automáticamente al volumen preprogramado.
- Para apagar**  
o el instrumento se apagará automáticamente después de dos minutos
- Indicador de pilas gastadas**
la luz roja y la luz verde parpadean únicamente durante el encendido.

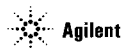

To Order:

www.agilent.com/healthcare/stethos

**Asia Pacific, Australia, China, India,
Japan, Korea, Malaysia, Singapore and Taiwan**

Agilent Technologies, Inc.
24F Cityplaza One
1111 King's Road
Taikoo Shing, Hong Kong
(+852) 3197 7777

Canada

Agilent Technologies Canada Inc.
Healthcare Business Centre
17500 Transcanada Highway
Kirkland, Québec H9J 2X8

1-800-291-6743 option 1
Monday to Friday, 8:30 a.m. to 5:00 p.m. EST

United States

Agilent Technologies, Inc.
Healthcare Solutions Group Headquarters
3000 Minuteman Road
Andover, MA 01810

1-800-225-0230
M-F, 8AM - 7 PM EST

Latin America, Brazil, Chile and Mexico

Agilent Technologies, Inc.
5200 Blue Lagoon Drive
9th Floor
Miami, FL 33126
(305) 267-4220

Europe

Agilent Technologies
Deutschland GmbH
Herrenberger Straße 130
71034 Boeblingen
Germany
fax (+49) 7031 464-2346

Austria:

Phone: (+43) 1 25125 - 600
Fax: (+43) 1 25125 - 7360
office_medical@agilent.com

Belgium/Luxembourg

(+32) 2 778-3085

Finland

(+358) 10 855 2450

France

(+33) 01 69 82 62 16

Germany

0130 860-781

Italy

(+39) 2 926081

Medical Distribution

Europe, Middle East, Africa

(+41) 22 780-6162

Netherlands

(+31) 20 547-6335

Poland

(+48) 22 608 7700

Russia

Phone (+7) 095 797 3979

Fax: (+7) 095 797 3903

Spain

(+34) 91 631 3100
902 30 40 50

Sweden

(+46) 8 506 488 12

Switzerland

(+41) 1 735-9225 (German Swiss)
(+41) 22 780-6111 (Suisse Romande)

United Kingdom

0870 607 76 77
0870 607 76 88

Copyright © 2000
Agilent Technologies
Printed in Canada 3/99
AW-M4504-91000-2 Rev. D

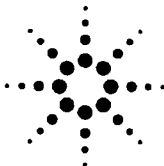

Agilent Technologies



Agilent Technologies



+H179M4504A3.

© Copyright 2000

Agilent Technologies

www.agilent.com/healthcare/stethos

Printed in Canada

AW-M4504-91000-2 Rev. D

 Printed on recycled paper